



VANTEON®

WIRELESS SOLUTIONS

vPRISUM™

Software-Defined Radio

The Vanteon vPrisum™ Software-Defined Radio (SDR) platform provides a highly integrated, small but very flexible system for high performance signal processing applications, at a very reasonable cost.

PRODUCTS

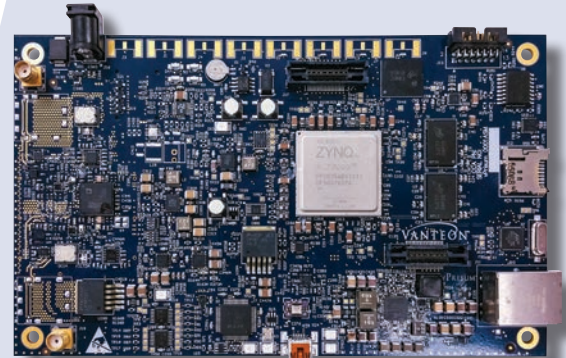

The platform consists of a single module that includes all digital and RF circuitry.

Electronic Systems

The vPrisum™ design can be leveraged into a wide variety of applications such as:

- Smart meter collection systems
- Low-cost base stations
- Security products
- Test equipment

Performance Specifications

- Support for bandwidths up to 56 MHz
- Broad RF frequency range from 70 MHz to 6 GHz with minimal to no hardware modification
- Capable of supporting thousands of endpoint radios per second
- Excellent sensitivity (function of selected waveform) through <1 dB Noise Figure
- Transmit power up to 30 dBm

Accelerate Your Design

Let Vanteon's engineering team help you get your products to market faster with a proven scalable SDR design.

Call us at 888.506.5677

Platform Features

The vPrisum™ platform offers the following key features:

- Xilinx Zynq Family FPGA for high performance signal processing
- Dual embedded ARM Cortex – A9 processors in the Zynq core
- Highly integrated, wide frequency range RF transceiver (AD9361)
- Performance enhancing RF Front End (RFFE) to improve on the AD9361 RFFE
- Dual RF inputs and outputs allow for multiple antenna systems like MIMO and switched diversity operation
- USB 2.0 High Speed, dual 1 Gb Ethernet, SD Card slot options
- Library of target-agnostic C/C++ software, VHDL firmware, and Simulink® modules providing core functions for radio operations:
 - Modulation/demodulation (ASK/AM, FSK/FM, PSK/PM, QAM, OFDM)
 - Digital down/up conversion
 - Symbol timing recovery/tracking
 - Carrier recovery/tracking
 - Filters (FIR, IIR, multi-rate, adaptive)
 - Automatic gain control
 - Channel coding
 - Multichannel TX/RX capabilities
 - FEC (e.g., convolutional, Reed-Solomon)
 - Spread spectrum coding
 - Customizable MAC



Celebrating over 30 years of service, innovation, and collaboration.